

BIATHLON - MODEL

# 1827 F BIONIC

**WORLD CLASS**  
IN A DIFFERENT  
LEAGUE

**ANSCHÜTZ**

EINFACH EINS WERDEN!



**NEW!**



*A quantum future – the next step. Futuristic design with superlative constructive features. Made for the best. So you can proudly say:*

**“MY ANSCHÜTZ”**



## 1827 F BIONIC **IN FOCUS**

The world is white.

The spectators are going wild, your heart is pumping. Adrenalin surges into your fingertips. The snow crunches under the ski.

You swing into the shooting stand and go to the firing position with a flowing movement. Now you bring your heartbeat in your body to an relaxed and calm mode. Control and stabilise the motions. An almost impossible undertaking ...

You stand still and focus. You immerse yourself in your task, block out the noise, the target is in sight.

No thinking, only self-belief. Your training becomes instinct, your rifle repeats at lightning speed and is absolutely smooth. The bullet is on its way from the barrel in 3.5 ms. No flinching.

Hit – the white disc flips up!

# 1827 F **BIONIC STOCK**

## AHEAD OF ITS TIME

Demands on a Biathlon rifle are exorbitant: It has to be fast, precise, light and robust but insensitive to ultra-low temperatures. All on a world-class level.

This can only succeed if three components work together: Experience, vision and feedback.

**Experience.** Like no other name, ANSCHÜTZ stands for progress in Biathlon – more than 95 % of all athletes put their faith in ANSCHÜTZ.

**Vision.** High-tech extends the limits of what is feasible. Lattice-structures in the grips revolutionise handling. The granulate used in the 3D printing is lighter, more robust and performs better in tensile and fracture tests. Invisible and very strong magnets integrated in the BIONIC stock hold the magazines absolutely securely.

**Feedback.** The impressions of the athletes and coaches are the inspiration for new experiments.

Experiments become experience.

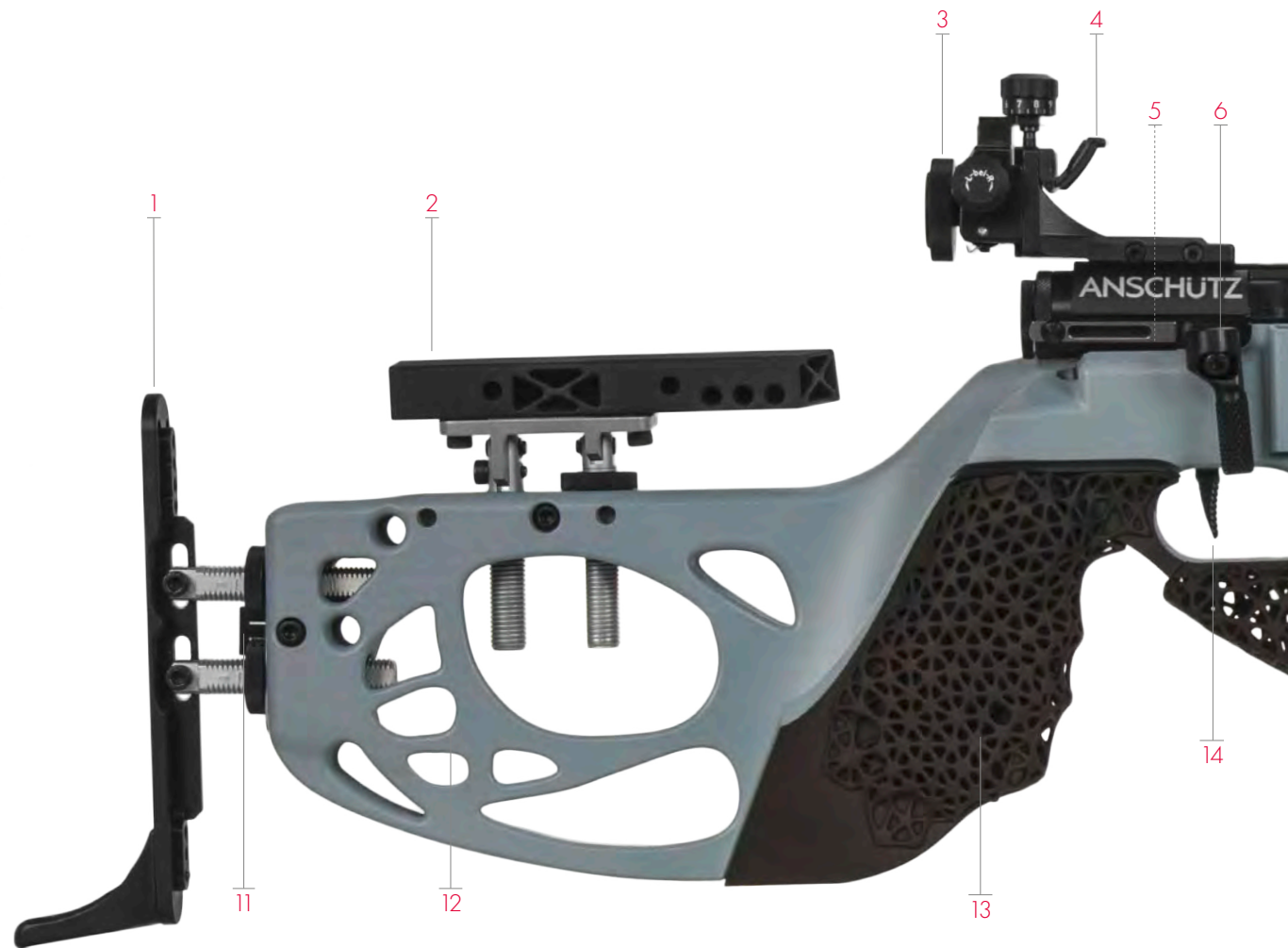

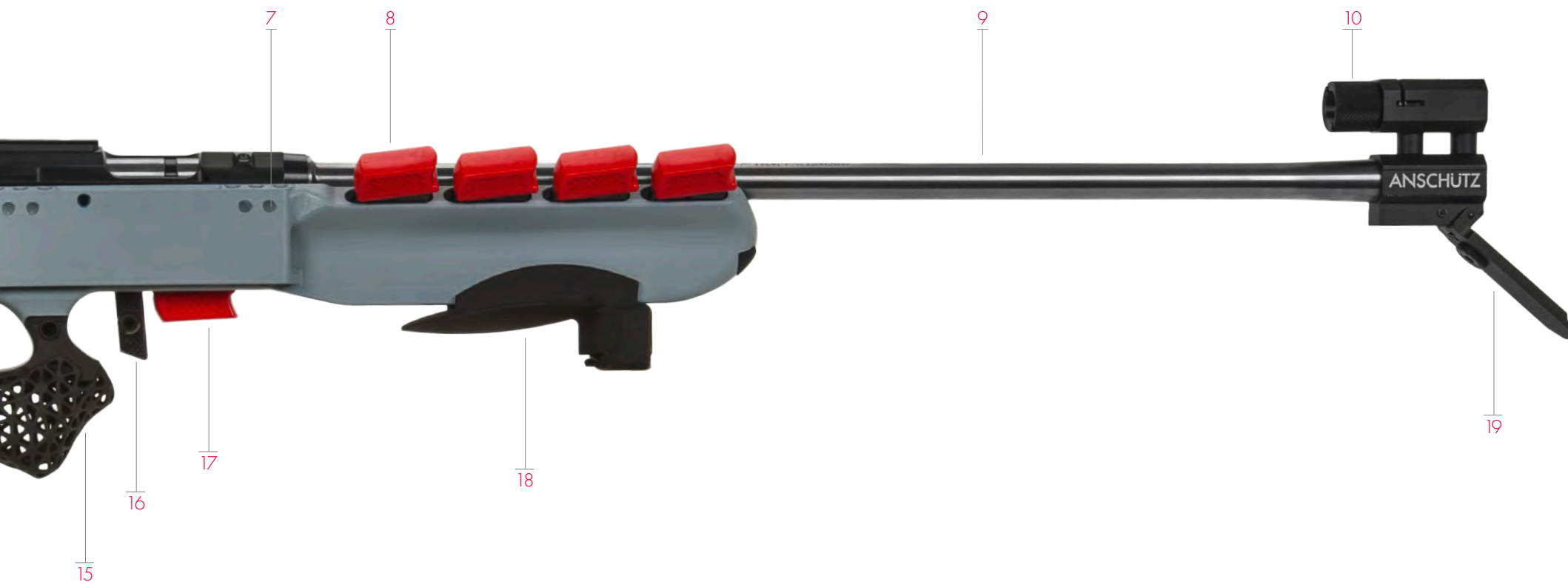

1 Butt plate, versatile adjustable

2 Cheek piece with integrated extra cartridge spender

3 Biathlon precision rear sight with snow cap

4 Snow cap to protect the rear sight

5 Sliding safety catch

6 Bolt handle of the straight pull action

7 Extra cartridge spender

8 Magazine holder with integrated magnets

9 Nitrided ANSCHÜTZ precision barrel, cold-tested

10 Biathlon front sight

11 Butt plate locking device

12 BIONIC stock

13 Grip in Lattice-structure

14 Trigger 5020, 90 g - 650 g

15 Middle hand rest in Lattice-structure

16 Magazine release lever

17 Magazine, 5 shot, easy to exchange

18 Hand stop

19 Snow cap to protect the front sight

# 1827 F **PLAY OF COLOURS**

## COUNTLESS VARIATIONS CAST IN THE SAME MOULD

Economical in weight and components - extremely light and focused on the essentials.

Versatile in appearance: The BIONIC stock is available in every RAL colour (colour-accurate)! The BIONIC stock, produced by 3-D printing can be laquered in over 200 colours - for your individual tone.

As if cast from a single mould.

### **Play of colours:**

- White .....(RAL 9003 Signal white)
- Grey .....(RAL 7001 Silver grey)
- Black .....(RAL 9005 Jet black)
- Red .....(RAL 3020 Traffic red)
- Orange.....(RAL 2011 Deep orange)
- Yellow .....(RAL 1018 Zinc yellow)
- Violet .....(RAL 4008 Signal violet)
- Blue .....(RAL 5015 Sky blue)
- Dark blue.....(RAL 5002 Ultramarine blue)
- Dark green.....(RAL 6002 Leaf green)





# 1827 F **COMFORT STOCK**

## UNCOMPROMISINGLY TRADITIONAL

The stock with the tried-and-tested components of an outstanding Biathlon rifle. For lovers of the classic wooden stock.

The extendible butt plate with its hook for the armpit can easily be adjusted to different body sizes: from young to adult. The vertically adjustable cheek piece enhances the individual adjustment.

The rifle that grows with you.

The special shape of the riser block COMFORT provides the biathlete with a consistently outstanding and extremely comfortable hold in position. A clamping piece in addition enables an individual length adjustment of the harness.



*Biathlon fascinates millions.  
More than 95% of all biathletes worldwide successfully  
shoot an **ANSCHÜTZ 1827 F Biathlon rifle.***



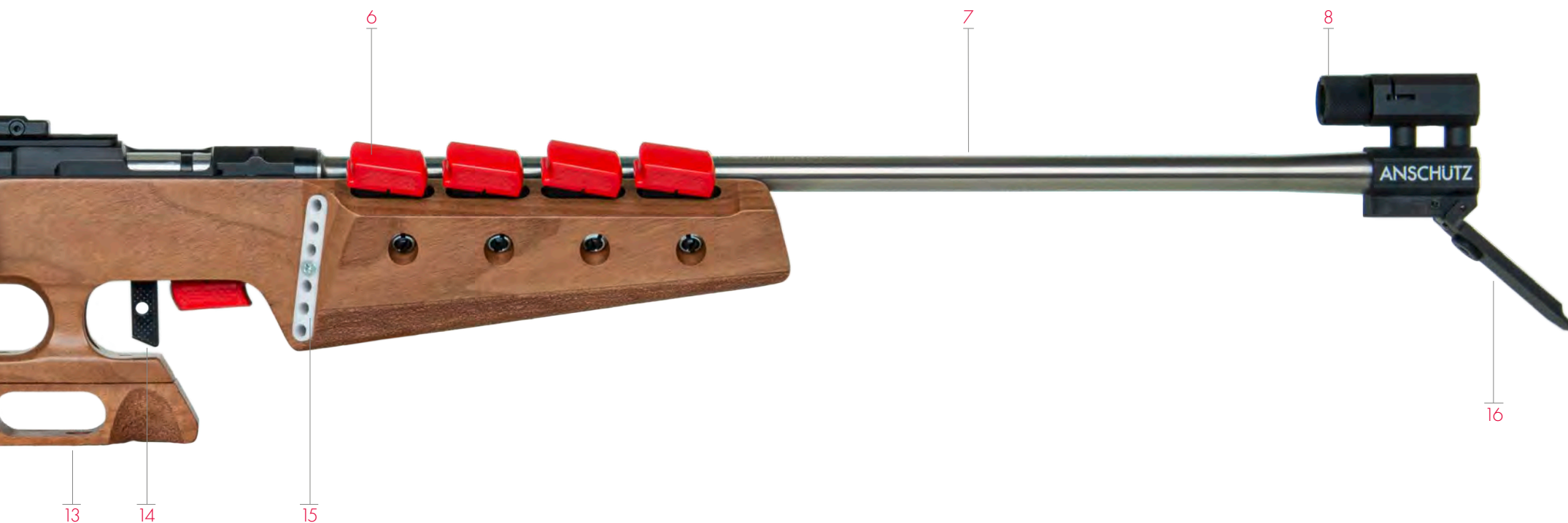

1 Butt plate, versatile adjustable

2 Cheek piece, versatile adjustable

3 Biathlon precision rear sight with snow cap

4 Sliding safety catch

5 Bolt handle of the straight pull action

6 Magazine holder

7 Nitrided ANSCHÜTZ precision barrel, cold-tested

8 Biathlon front sight

9 Butt plate locking device

10 Clamping piece for harness

11 Stippled checkering

12 Trigger 5020, 90 g - 650 g

13 Riser block COMFORT

14 Magazine release lever

15 Extra cartridge spender

16 Snow cap to protect the front sight

GOLD FOR GOLD PERFORMANCE

## THE GOLDEN ANSCHÜTZ RIFLE FOR GABRIELA KOUKALOVÁ

For her outstanding achievements Gabriela Koukalová received a gold plated ANSCHÜTZ 1827 F Biathlon barreled action.





1827 F

## **WRITING SPORTS HISTORY**

Almost 50 years lie between the two photos - and the proof of how much ANSCHÜTZ has shaped the Biathlon, indeed decisively shaped it. Essential components of today's competition rules stem from Dieter Anschütz: The change from big- to small bore calibers opened up the sport to the general public; more than 95 percent of the athletes worldwide shoot with ANSCHÜTZ rifles. Significant impulses originate from the creative hotbed of ANSCHÜTZ.



Today we are once again on the verge of a technological leap. In cooperation with the umlaut company, 3D printed stocks are being produced which can be adapted to the individual athlete and are close to make-to-order-production. The lattice-structure reduces the weight of the grip and support without any loss of strength of the barrelled action. The bedding is based on a sophisticated milled groove which is coated with synthetic resin.

Each rifle is tested in the cold chamber. Biathlon takes place at temperatures as low as -20 °C – an absolute acid test for the material and a guarantee for athletes that everything will work in competition as it should do. In every situation.

# 1827 F **THE BARRELED ACTION** SPEED WINS

## THE ULTIMATE IN BIATHLON RIFLES

Highly complex interplay of precision engineering and material, high-tech, state-of-the-art production and know-how. Everything in the smallest possible space. Created for the will to hit the target - the will to win under any circumstances and in any conditions.

## PRECISION BARREL

Conically tapered. Nitrided surface, hardened at 500 °C. Withstands temperatures as low as -30 °C and still produces excellent results. With a snow cover to provide protection from the weather.



## BOLT - A REVOLUTION

The Fortner straight pull action enables extremely rapid repeating with a completely stable firing position. The bolt with seven locking-balls for perfect safety.



5 shot, caliber .22 l.r.



## MAGAZINE

Made of hardened steel. Blued with a protective layer for long-lasting protection against corrosion. Non-slip, cold-resistant polymer for secure changeover from used to loaded magazines.

## TRIGGER - A MASTER STROKE

For ultra-quick trigger release. Virtually noiseless. Minimum trigger weight in accordance with the competition rules with the possibility of adjustment to the needs of the athletes.

The location in the rifle with the decisive moment: 50 high-precision parts in harmony in the tightest of spaces for a single task – creating the perfect “interface”. The interface between human and rifle. Near to unique, and meanwhile adapted by other manufacturers.

**There is nothing better.**



More than 50 high-precision parts

- Adjustable match two-stage trigger 5020, set in factory to 550 g, adjustable from 90 g - 650 g
- Ergonomic and silent safety catch operation

# 1827 F THE STOCK AND ITS DNA

## PAVING THE WAY: THE FORM OPTIMISES THE FUNCTION AND PURPOSE

The shape? Maybe getting used to. The advantage: undisputed and proven in extreme tests! The **BIONIC stock** was designed by computer. It is the ultimate quintessence of the competition rules of the International Biathlon Union (IBU) and the requirements of the athletes. Precisely calculated for perfect handling, for the highest stress with the lowest possible load and for fatigue-free comfort.

The **form** of the grip and the vertically adjustable fore-end is based on the commonalities of dozens of athletes' handprints - every 1827 F contains a piece of successful athlete DNA! The grips are available in three sizes for the market launch.

After the marriage of the stock and barrelled action the **bedding area** can be injected with a two-component epoxy resin. This results in a negative of the inner honeycomb structure which adheres immovably.

Distribution of forces: Importance is attached to minimum weight with maximum stiffness in the simulation-based bionic design.

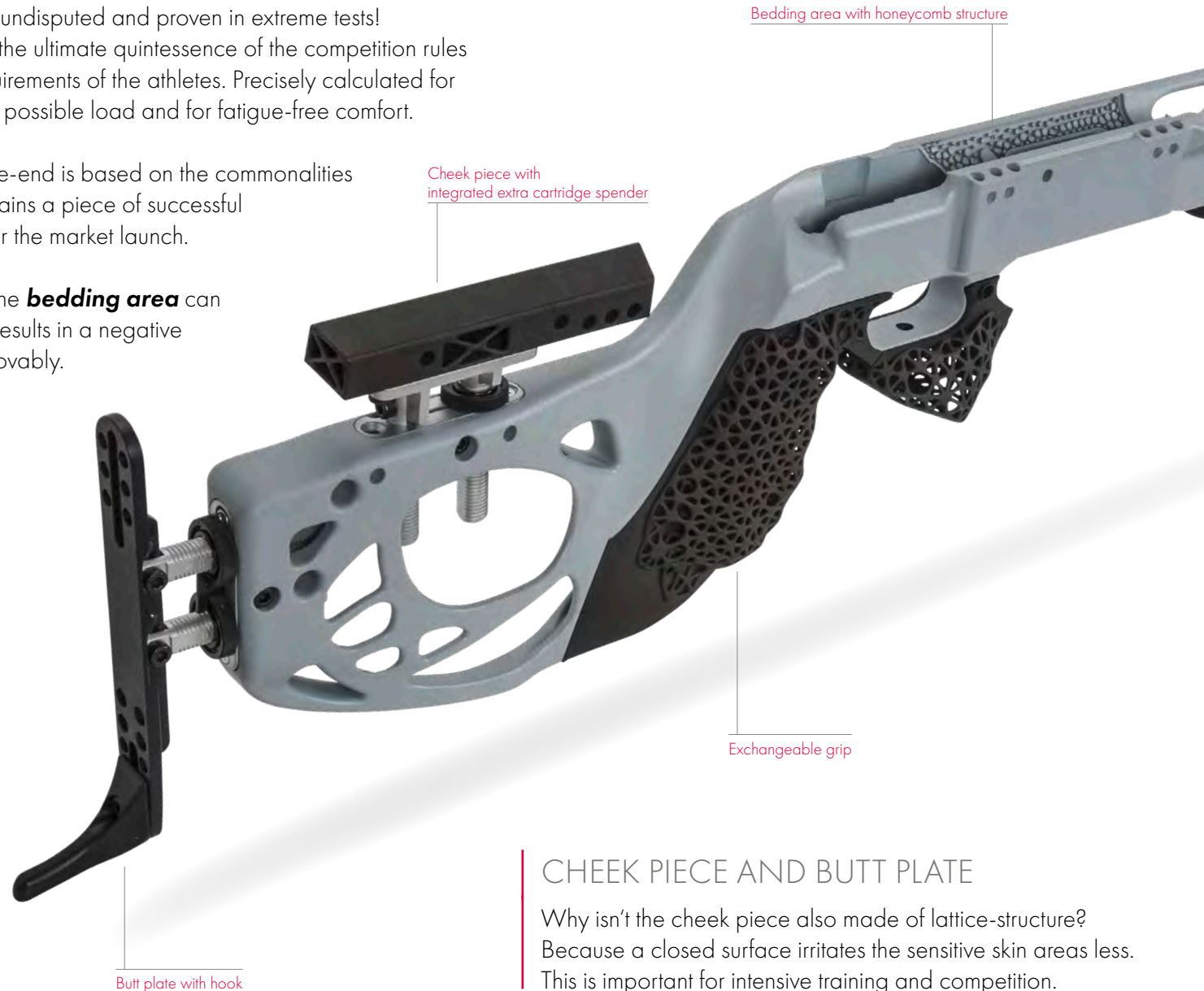
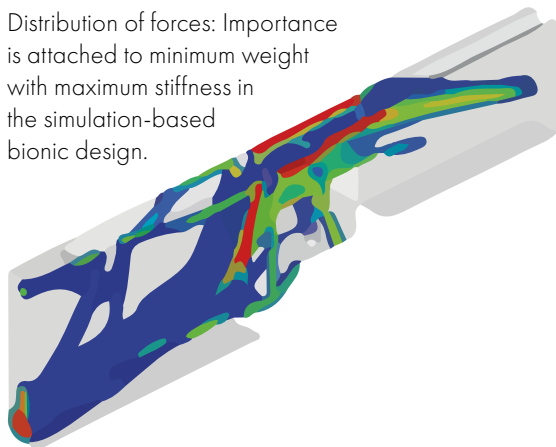

### CHEEK PIECE AND BUTT PLATE

Why isn't the cheek piece also made of lattice-structure? Because a closed surface irritates the sensitive skin areas less. This is important for intensive training and competition.

# 1827 F THE STOCK AND ITS COMPONENTS

VARIABLE FOR ATHLETES WHO GROW WITH THEIR RIFLE



## GRIP AREAS

The grip, the middle hand rest and the hand stop was developed according to the specifications of athletes: ergonomic, non-slip, secure.



# 1827 F THE STOCK AND ITS COMPONENTS

## INPUT FROM THEORY AND PRACTICE



### HARNESS

The partially padded harness supports rapid changeover from the shoulder to the firing position. This new Biathlon harness has been developed in cooperation with Deuter Sport GmbH, a worldwide leading manufacturer of harnesses. We have included Deuter's experience of more than 100 years in our concept for this product in order to provide best possible comfort to biathletes.



**ANSCHÜTZ**

EINFACH EINS WERDEN!

BIATHLON RIFLES OF THE FUTURE

**BIONIC STOCK FROM A 3D PRINTER**



DEVELOPED ACCORDING TO THE SPECIFICATIONS OF ATHLETES

**ERGONOMIC, NON-SLIP, SECURE**



## ABOUT **umlaut**

umlaut is a global, full-service, cross-industry, end-to-end company that offers advisory and fulfilment services to clients all over the world. In-depth domain expertise, broad practical knowledge and interdisciplinary collaboration allow them to add value, quality and focus to their clients' organisations, services and products, in disruptive times in which industries are increasingly converging.

Within an able and agile collective of 20 consultancies and engineering firms spread across 50 locations all over the world, 4,300 specialised experts and engineers provide innovative solutions and transformations across all industries and their various intersections as well as serving the public sector and developing organisational cultures, structures and processes.

For more information please visit: [umlaut.com](http://umlaut.com).

# 1827 F **MODULAR SYSTEM**

YOUR PERSONAL 1827 F – ACCORDING TO YOUR WISHES!

## 1. CHOOSE A BARRELED ACTION



Length of barreled action .....730mm  
 Barrel length ..... 21.7" (550mm)  
 Muzzle diameter ..... 19mm

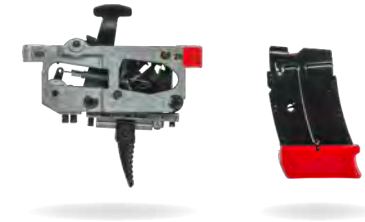

**Barreled action equipped with two-stage trigger 5020,**  
 adjustable from 90 g – 650 g  
 trigger weight adjusted to 550g.  
**and 5 shot Biathlon magazine.**



## 2. CHOOSE A STOCK



### **BIONIC Stock**

Length of pull ..... 360 mm  
 Length of stock .....750 mm  
 Material ..... Polymer  
 Colour ..... Grey/Black  
 Disired colour .....RAL-colours



### **COMFORT Stock**

Length of pull ..... 360 mm  
 Length of stock .....750 mm  
 Material ..... Walnut, oiled



### 3. CHOOSE A GRIP SIZE

Only available with BIONIC stock



**Grip S Lattice**

Corresponds to glove size 7,5  
Shape „classic“



**Grip M Lattice**

Corresponds to glove size 8,5  
Shape „pistol grip“



**Grip L Lattice**

Corresponds to glove size 9,5  
Shape „classic“

### 4. RECOMMENDED ACCESSORIES



**Harness Light**

The classic ANSCHÜTZ harness - reliable and proven  
Weight: approx. 300g



**Harness Feedback**

Due to the compact design, this harness gives the athlete more contact  
Weight: approx. 280g



**Biathlon rear sight set 6827**

Incl. aperture inserts and tools



**Sight riser block Biathlon 6866**

Height, 8 mm



**Rear sight extension**

For eyeshade 1827F-55



**Rubber eyeshade 6700-20**

For a clear view



**Biathlon sling set**

Consisting of target sling 4736, arm sling 4735-U1 and hand stop SLS



**Arm sling 4732**

For right and left handed shooters, in sizes S, M or L



**Soft case 9210**

Black/red



**Soft case 9212**

Black/blue



# | 1827 F TECHNICAL SPECIFICATIONS

Depending on the selected configuration the technical specifications of your model 1827 F Biathlon rifle will be different.

The total weight is between 3.456 g – 3.600 g  
The total length is between 1020 mm – 10140 mm

## CONFIGURATION EXAMPLES

### **Model 1827 F, 21.7" (550 mm) barrel, BIONIC stock, grip size L**

Total length.....1020 mm

Total weight .....approx. 3.456 g

### **Model 1827 F, 21.7" (550 mm) barrel, COMFORT stock**

Total length.....1040 mm

Total weight .....approx. 3.600 g

### **Barreled action**

Total length.....730 mm

Barrel length.....21.7" (550 mm)

Muzzle diameter ..... 19 mm

Weight approx. ....2.020 g

Caliber ..... .22 l.r.

Number of grooves.....8

Twist rate .....420 mm

### **Magazine**

Number of shots.....5

Weight approx. ....32 g

### **Trigger 5020**

Kind of trigger.....Two-stage trigger

Adjusted to .....550 g

Range of adjustment.....90 g – 650 g

Weight approx. ....170 g

### **BIONIC stock, laquered**

Length of stock.....750 mm

Length of pull.....360 mm

Weight approx. ....1.330 g

Butt plate.....Aluminum

### **COMFORT stock, oiled**

Length of stock.....750 mm

Length of pull.....360 mm

Weight approx. ....1.490 g

Butt plate.....Aluminum

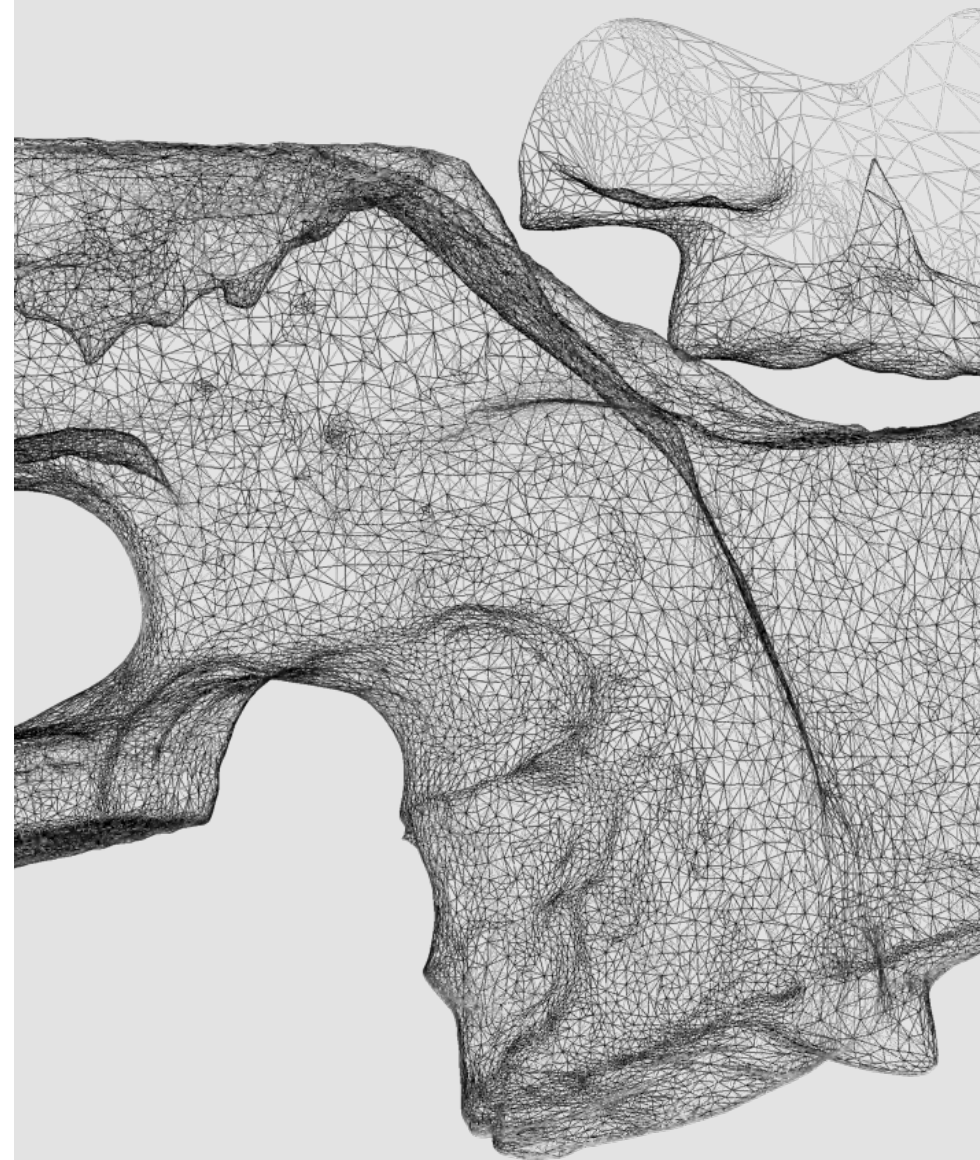

SELECTABLE COMPONENTS - COMPLETE CONFIGURATION		Selection
STOCK	COMFORT stock, walnut oiled	■
	BIONIC stock, grey/black	□
	BIONIC stock, laquered in desired RAL-colour	□
Selectable only when selecting the BIONIC stock, no surcharge		
GRIP SIZE	Grip S (classic), corresponds to glove size 7.5	Ⓟ
	Grip M (pistol grip), corresponds to glove size 8.5	Ⓟ
	Grip L (classic), corresponds to glove size 9.5	Ⓟ

RECOMMENDED ACCESSORIES		Selection
SIGHT SET / OPTICS	Biathlon rear sight set 6827	□ 000932
	Rubber eyeshade 6700-20	□ 001405
	Rear sight extension 1827 F-55	□ 008441
	Sight riser block Biathlon 6866, 8 mm	□ 011702
HARNESS	Harness Light, approx. 300 g	□ 011817
	Harness Feedback, approx. 280 g	□ 015390
TARGET SLINGS	Biathlon sling set – target sling, arm sling und hand stop SLS	□ 011470
	Target sling 4736, right (length 210 mm)	□ 009188
	Arm sling 4735, left (length 260 mm)	□ 009205
	Arm sling 4732 right/left, (size M, 380 mm)	□ 011151
SOFT CASE	Biathlon soft case 9212, black/blue	□ 009186
	Biathlon soft case 9210, black/red	□ 001488

RECOMMENDED ACCESSORIES		Selection
MISCELLANEOUS	5 shot magazine, replacement	□ 001160
	Hand stop SLS with clamping for target sling	□ 001086
	Thumb rest enlarged, right or left hand version	□ 008030 / 008031
	Firing pin for 1827 F Biathlon	□ 001228
	Mounting tool 4729, for firing pin Fortner Biathlon	□ 001486
	Extra cartridge spender for 6 cartridges, to screw on stock	□ 008442
	Hook for biathlon butt plate	□ 003417
	Cleaning kit 507 – cord and wicks	□ 001491
	Damping ring for Biathlon 1827 F-40	□ 001463
	Bolt handle Biathlon, right or left hand version	□ 003353 / 008024
Torque wrench 4506, size SW4, 4-12 NM	□ 001176	

STOCKS		Selection
COMFORT stock, walnut oiled	□	014819
BIONIC stock, grey/black - grip size S, M or L	□	
BIONIC stock, laquered in desired RAL-colour	□	

BARRELED ACTIONS		Selection
1827 F Biathlon Sprint nitrided, right hand version	□	010067
1827 F Biathlon Sprint nitrided, left hand version	□	007659

■ Included in basic price

□ Optional – with surcharge

Ⓟ Only for BIONIC stock

# ANSCHÜTZ

EINFACH EINS WERDEN!

## J.G. ANSCHÜTZ GmbH & Co. KG Jagd- und Sportwaffenfabrik

Daimlerstraße 12 · 89079 Ulm / Germany  
Fon +49 - (0)731 - 40 12 - 0  
Fax +49 - (0)731 - 40 12 - 700  
[www.anschuetz-sport.com](http://www.anschuetz-sport.com)  
[www.facebook.com/OfficialAnschuetz](https://www.facebook.com/OfficialAnschuetz)  
[www.youtube.com/AnschuetzGmbH](https://www.youtube.com/AnschuetzGmbH)  
[www.instagram.com/AnschuetzGmbH](https://www.instagram.com/AnschuetzGmbH)

Your Dealer

## 1827 F BIONIC From roots and wings

„ANSCHÜTZ researches and produces at high-tech level. We draw on a source of traditional craftsmanship which has never become old-fashioned.

This is a tradition which ultimately means consistency and perseverance and not letting ourselves be seduced by short-lived trends, even if they may be tempting.

We therefore see ourselves as the guardians of excellence ‚Made in Germany‘. We manufacture almost all the components of our rifles ourselves.

The pride of our employees in ‚their‘ company is based on the knowledge of their extraordinary responsibility – in the same way as the ANSCHÜTZ company is proud of its employees!“

*Jochen Anschütz*  
**Jochen Anschütz**  
President

